

Stock Hydraulic i-Valve Lift Controller

We hold in stock Hydraulic Lift Controllers for the Bucher i-Valve Pump Unit up to 28 kW with a maximum of 40 Amp Contactors. Based around the DMG Playboard 3 32-bit Microprocessor; out of the box our controllers are setup to suit a Bucher iCon and Parameter Card, 240 VAC Door Operator and 110 VDC retiring cam. The Bucher iCon and Parameter Card are not included as standard but are available as an optional extra.

These units are then tailored by our technicians to suit your specific site requirements.

Features of our stock lift controllers



- 3 phase supply
 - 2 to 8 floors
 - SAPB or Down Collective operation
 - 24 hour battery test
 - 4 point safety chain
 - Photocell input NO/NC
 - Floor level indication
 - Motor thermistor input
 - Auto shaft learn
 - Last 60 faults logged
 - Advance door opening
 - Star Delta starting
 - Simplex control
 - Set for 1 x 240 VAC Car Door Operator
 - Timed car lights off
 - One position fire recall
 - Out of service
 - Short floor capability
 - Selective or Simultaneous door control
 - Over 50 faults detected
 - Visual I/O status
- Setup to suit a Bucher iCon and Parameter Card (not included)
- Set for a 110 VDC Retiring Ramp voltage
- Full load bypass and lift overload control
- Programmable return zones (Weeks, Days, Hours, Minutes)
- Programming module with LCD screen with every panel
- Programmable 4 digit code for car call acceptance

Lift Controllers outside of this specification are available from our Bespoke Range of Lift Controllers.

See the reverse for information on our Customisation Options and Shaft Kits

Customisation Options

Our skilled Technical Engineers can carry out a range of modifications to the stock controller to match your site requirements.



Single phase supply
 Floors 9 to 16
 Full collective operation
 Overspeed Governor trip and/or reset
 BMS interface

Duplex/Triplex/Quadraplex control
 Direct Online or Soft start
 4 position fire recall
 A3 control

Controller set for up to 2 x 3 phase Car Door Operators
 16 way output card to drive existing displays
 Controller set for 2 x 240 VAC Door Operators (Side A & B)
 The addition of resistors for DC Door Operators (GAL, DUPAR or H&C)
 Customisation of the Retiring Ramp voltage to suit site conditions

Shaft Kits

In order to offer maximum flexibility and choice, we offer three tiers of Shaft Kit.

All our Lift Controllers come complete with a fully integrated Hard Wired Shaft Kit, the elements of each kit will depend on the type of lift but generally include:

- | | |
|--|--------------------------------|
| Emergency Operation Box | Final Limit Switch Support Kit |
| Door Zone Kit | Magnetic Deceleration Switches |
| Relevelling and Door Zone Kit | H Supports |
| Magnets/Support Bracket Kit (Door Zone) | |
| Magnets/Support Bracket Kits (Relevelling) | |
| Final Limit Switch Kit (Traction/Hydraulic Direct) | |
| Final Limit Switch Kit (Traction/Hydraulic Indirect) | |
| Encoder Counting Kit & Rope 60/120m | |

The Part Pre-Wired and Fully Pre-Wired Shaft Kits are supplementary and can be added to your package to provide a fully integrated plug and play lift electrical system, ensuring a quick and error free installation.

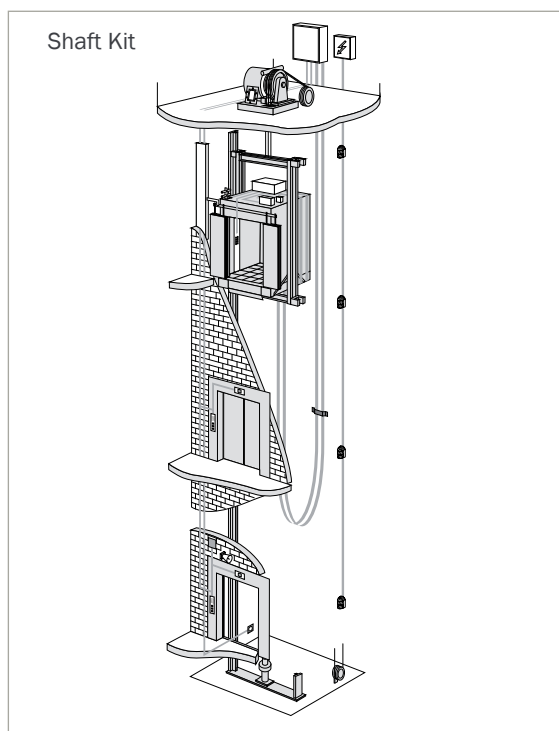

Pre-wired Electrical System

Complete your refurbishment package with our fully pre-wired lift electrical system.

Our pre-wired electrical system is fully compatible with our range of comprehensive range of stock lift controllers and stock car and landing push buttons and indicators.

All Car Operating Panel, Landing Operating Panel and Landing Indicator Panel are fitted with *Plug & Play* connectors, when you take the pre-wired electrical system together with our stock Car and Landing fixtures.

Plug & Play connectors utilised throughout the our pre-wired electrical system ensure a speedy and error free installation resulting in less time on site and less down time for the client.

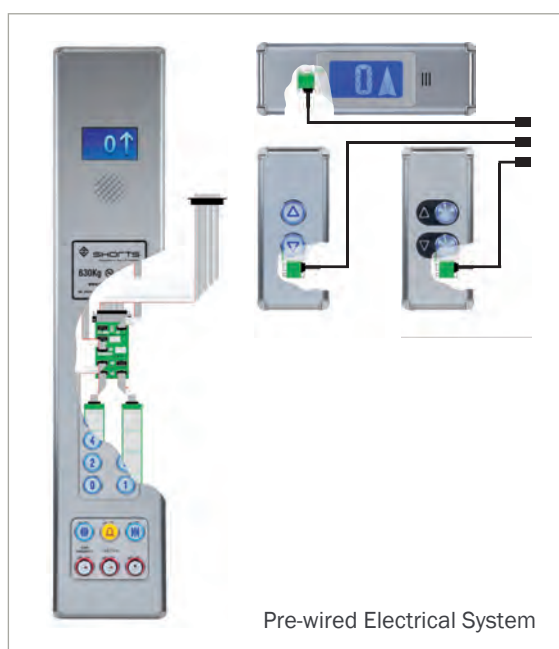

Contact Shorts

6 Station Road, Bradford BD1 4SF T: 01274 305066 info@shorts-lifts.co.uk
 Unit 7, First Floor, 1 Cobden Close, Bromley BR2 9JF T: 020 7394 3080 info@shorts-lifts.co.uk

